



Electric Druid VCLFO 10

Introduction	1
Block diagram	2
Features	2
<i>Four LFO ranges: from 0.05Hz to 102.4Hz</i>	2
<i>16-bit waves and 10-bit LFO output resolution</i>	2
<i>31.25KHz sample output rate</i>	2
<i>8-bit resolution on the control voltages</i>	2
<i>Logarithmic control response over 1:256 range</i>	3
<i>Sixteen output waveforms, in two sets</i>	3
<i>Random waveform</i>	3
<i>Sample-and-Hold</i>	3
<i>Wave Distortion CV input</i>	4
<i>Ability to sync LFO and S&H</i>	4
Pinout Diagram	5
Application Notes	6
<i>Example circuit: Multi-waveform LFO with Frequency and Level CVs</i>	6
<i>Example circuit: Single Supply LFO for effects/stompbox use</i>	6
Digital options	6
CV Inversion Configuration	7
Wave set selection	7
Wave smoothing	7
<i>Using potentiometers for CVs</i>	7
External CV inputs	8
<i>Using a rotary switch to select LFO Range, Sync Mode, or Waveform</i>	8
<i>Using digital signals to select LFO Range, Sync Mode, or Waveform</i>	8

Introduction

This voltage-controlled low frequency oscillator uses a PIC microprocessor to create a very versatile and powerful LFO. All LFO parameters can be controlled by 0-5V control voltages or digital inputs.

This new version offers significant improvements over the Version 9 chip, including higher PWM frequency, selectable LFO range, no need for an external clock crystal, and much better waveform resolution. In addition, there are eight new waveforms available, including a wandering random waveform. The CV inputs can be inverted to make use with summing op-amps more convenient (see the application notes for examples). This saves circuit complexity for many applications. There is also a smoothing filter available to reduce clicks caused by control feedthrough in application circuits.

Block diagram

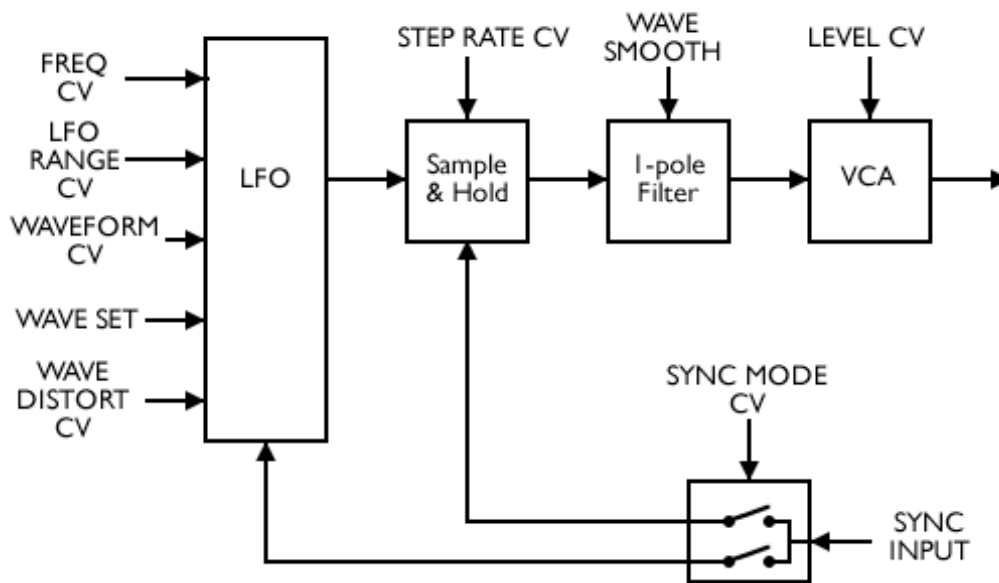

The VCLFO10 chip can produce 16 waveforms, including a noise source and a wandering random voltage. The basic LFO frequency is controlled by **FREQ CV**, which can have its range switched over four octaves by the **LFO RANGE CV**. The **WAVE SET** input selects one of two sets of eight waveforms, and the **WAVEFORM CV** selects one of the 8 waveforms. The LFO wave shapes can be modified by the **WAVE DISTORT CV**. The output from the LFO is fed to the sample-and-hold. This has its own rate set by **STEP RATE CV**, and can be disabled entirely. From there the signal goes to the optional wave smoothing filter, which is handy for reducing clicks if the LFO is used to modulate sensitive audio circuits like VCAs. Finally, the **LEVEL CV** sets the output level.

Features

Four LFO ranges: from 0.05Hz to 102.4Hz

The LFO can cover eleven octaves in four eight-octave ranges. The range is set by **LFO RANGE CV** to one of four options: 0.05Hz to 12.8Hz, 0.1Hz to 25.6Hz, 0.2Hz to 51.2Hz, 0.4Hz to 102.4Hz.

16-bit waves and 10-bit LFO output resolution

The internal waveforms and calculations have been improved beyond the original's 8-bit waves. This version uses 16-bit wave data with interpolation to give the smoothest possible result. The final PWM output is 10-bit.

31.25KHz sample output rate

The PWM output frequency is 31.25KHz., a big increase on the 19.5KHz of the previous generation chip. This allows the PWM output to be heavily filtered for a smooth analogue output.

8-bit resolution on the control voltages

The control voltage inputs are sampled at 8-bit resolution, and at a rate between 250Hz and 500Hz depending on the waveform. This is sufficient for modulation of a low frequency source like an LFO.



Logarithmic control response over 1:256 range

The frequency CV covers the full range in eight even octaves, for example 0.05-0.1Hz, 0.1-0.2Hz, 0.2-0.4Hz, 0.4-0.8Hz, 0.8-1.6Hz, 1.6-3.2Hz, 3.2-6.4Hz, 6.4-12.8Hz. The fact that this input is logarithmic means the FREQ CV input can use linear pots and still have a musical feel.

Sixteen output waveforms, in two sets

The chip can produce 16 output waveforms, shown below. These are selected by the voltage on Pin 12 (WAVEFORM) and the digital level on Pin 6 (the WAVE SET selection input).

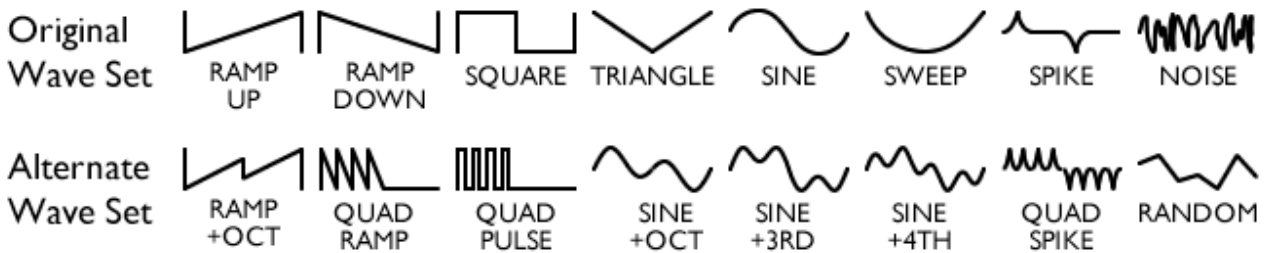

Random waveform

One of the most exciting new additions is the Random waveform. This moves linearly between random points chosen at the LFO rate. Sometimes the points will be far apart and the output will move fairly quickly, other times they're closer together and it moves only very slowly. The waveform is great in any situation where you might have used a triangle wave, but where some more unpredictability is a benefit, such as PWM modulation in synth oscillators for complex pads, or BBD modulation for chorus and flangers.

The Random waveform is also affected by the Wave Distort CV.

Sample-and-Hold

The selected waveform can be further modified by the sample-and-hold module. With Pin 11 (STEP RATE CV) below approximately 0.157V (a ADC reading of 8), this feature is disabled. Higher voltages set the rate for the sample-and-hold.

The previous generation chip only updated the rate when a new sample was taken. That is no longer the case, and changes to the STEP RATE CV now take effect immediately.

Wave Distortion CV input

The selected waveform can be distorted using the WAVE DISTORT input. This regards each waveform as consisting of two equal sections - with a square wave, these would be the high and low parts respectively. Usually each section occupies 50% of the waveform's total length, but the WAVE DISTORT input allows you to modify this until one half of the wave occupies almost all the time.

This is better seen with a diagram:

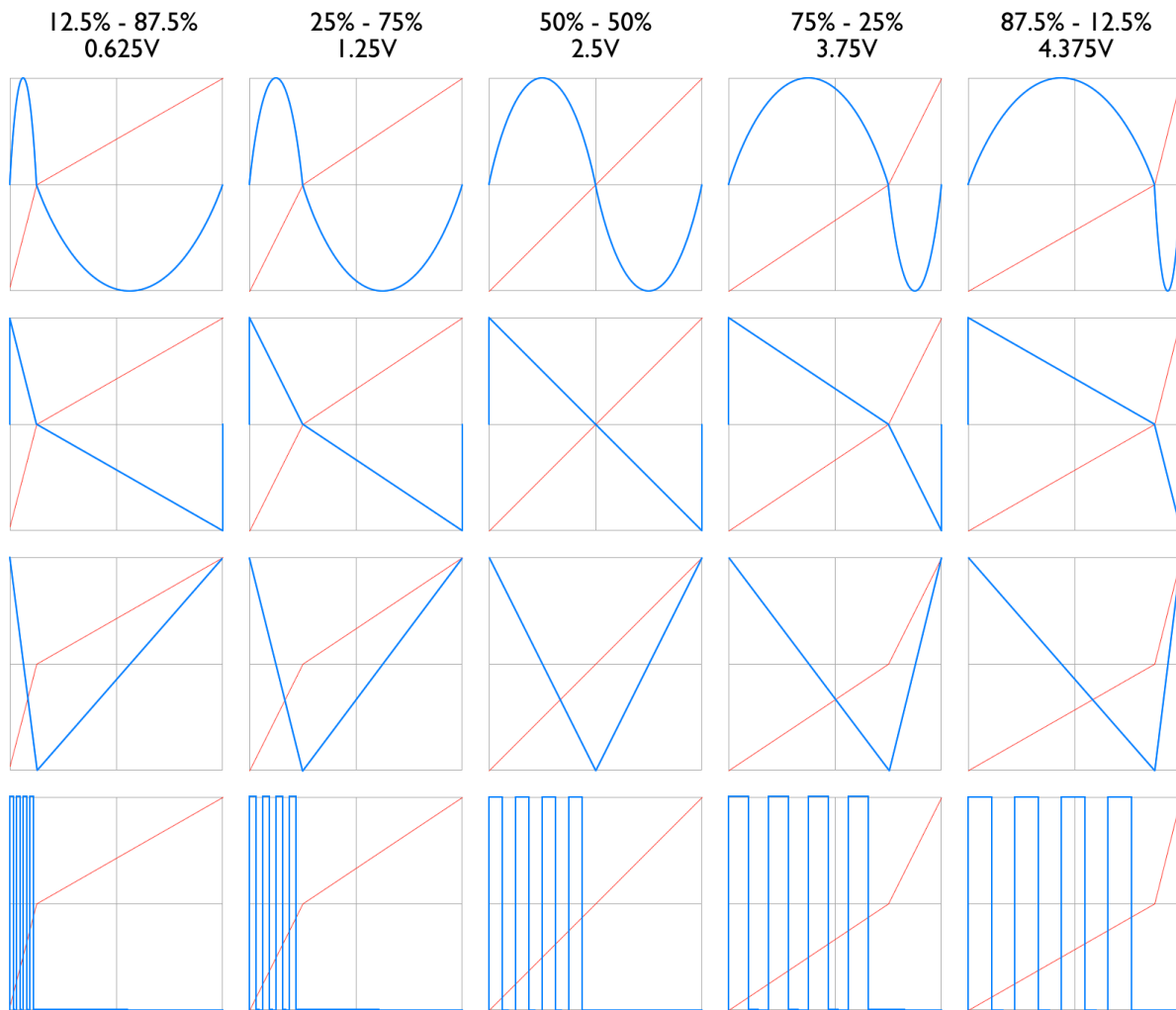

The top row shows the effect of the WAVE DISTORT CV on the SINE wave, whilst the following rows show the effect on the RAMP DOWN, TRIANGLE, and QUAD PULSE waveforms. Other waves (excepting NOISE) are affected similarly.

Ability to sync LFO and S&H

The SYNC IN input allows you to use a 0-5V pulse signal to reset the phase of either the LFO or the S&H. The SYNC IN MODE input voltage selects either LFO, S&H, or both to be reset by the SYNC IN pulses.

Note that this input provides hard synchronization of the LFO and S&H, and is not an external clock. The effect of an externally-clocked S&H can be achieved by setting a very slow S&H rate with a faster SYNC IN pulse rate.

Pinout Diagram

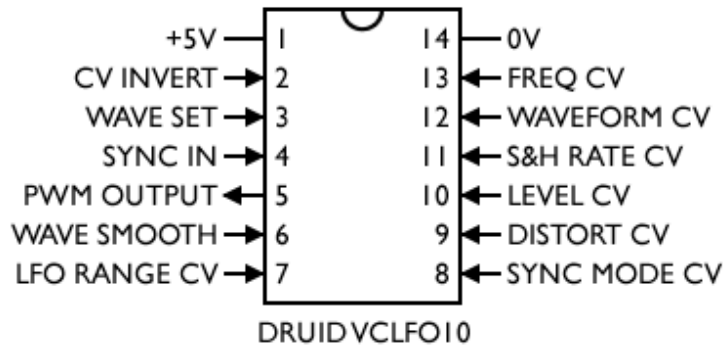

Pin	Function	Details	Notes
1	+5V	Power supply	
2	CV INVERT	0-5V digital input Config option	NC/+5V - No CV inversion 0V - All CVs inverted
3	WAVE SET	0-5V digital input	NC/+5V - Original wave set 0V - Alternate wave set
4	SYNC IN	0-5V digital input	Can reset either LFO, S&H, or both
5	PWM OUTPUT	0-5V digital output	PWM output at 31.25KHz
6	WAVE SMOOTH	0-5V digital input	NC/+5V - No smoothing 0V - Wave smoothing filter applied
7	LFO RANGE CV	0-5V analogue input	0 - 0.05 to 12.8Hz 1 - 0.1 to 25.6Hz (+1 octave) 2 - 0.2 to 51.2Hz (+2 octaves) 3 - 0.4 to 102.4Hz (+3 octaves)
8	SYNC MODE CV	0-5V analogue input	0 - Sync disabled 1 - Reset S&H 2 - Reset LFO 3 - Reset both
9	WAVE DISTORT CV	0-5V analogue input, with 2.5V offset	8 bit, values from 20 to 235 Produces phase distortions of the waveform
10	LEVEL CV	0-5V analogue input	8 bit, values from 0 to 255 Controls overall output level
11	STEP RATE CV	0-5V analogue input	8 bit, values from 8 to 255 (Below 8 is off) 0.2 Hz to 51.2 Hz
12	WAVEFORM CV	0-5V analogue input	3 bit, values from 0 to 7 Selects waveform from the current set of 8



Pin	Function	Details	Notes
13	FREQ CV	0-5V analogue input	8 bit, values from 0 to 255 Controls output frequency over 8 octaves
14	0V	Power supply	

NC = Not connected

Application Notes

Schematics for the example circuits are shown at the back of the datasheet.

Example circuit: Multi-waveform LFO with Frequency and Level CVs

The circuit on the following two pages shows many of the features of the chip and introduces many useful circuit elements.

The chip is configured with pin 2 tied low, so all CV inputs are inverted. The inputs for Frequency CV and Level CV have inverting mixers attached that allow modulation of the pot setting by an external control voltage. The other inputs are wired simply with pots. The same mixer circuit can be applied to any or all inputs as necessary.

The circuit uses a two-stage filter giving a 4-pole response for excellent PWM frequency suppression. The second filter stage applies a gain of two and allows the signal offset to be adjusted to ensure the waveform is centred around zero.

Example circuit: Single Supply LFO for effects/stompbox use

The final example circuit shows an LFO that can be added to 9V effects/stompbox circuits. It can replace a simple LFO in many designs (chorus, flangers, phasers, and tremolos, for example) and will provide many more options and sounds.

Digital options

There are three digital option pins on the chip. The pins have internal pull-ups, so if left unconnected, they default to the same behaviour as the previous VCLFO9 chip. If grounded, they offer a further possibility.

Option	Pin	Unconnected / +5V	0V
CV inversion	2	CVs not inverted	All CVs are inverted
Wave Set Selection	3	Original waveform selection	Alternate waveform selection
Wave Smooth	6	Wave smoothing off	Wave smoothing on



CV Inversion Configuration

The CV inputs can be inverted to make life easier when using external summing op-amps for mixing CV inputs and control knobs settings. Note it is not possible to only invert some inputs. All the CV inputs (pins 7-13) are affected. However, it is equally simple to use pots and switches with inverted inputs - just reverse the minimum and maximum voltages for the pot or switch.

This pin is only tested by the firmware at start-up, so cannot be switched during use. It is instead intended to allow the chip to be configured by the hardware for specific applications.

Wave set selection

There are two different waveform selections available. With the WAVE SET pin high or unconnected, the original VCLFO 9 waves are selected. If the pin is grounded, the alternate waveforms are selected. All that is required is a simple SPST switch from the pin to ground to select between the two waveform sets.

Wave smoothing

Sometimes when using the LFO output to drive a VCA or similar sensitive audio circuit, the sharp edges of some waveforms can cause clicks in processed audio due to CV feedthrough. The wave smoothing feature applies the exact digital equivalent of a simple RC lowpass before the wave leaves the chip and can help prevent clicks in VCAs, optical tremolos, and similar vactrol-controlled circuits. The filter has a cutoff frequency of around 1KHz, and this gives a rise time on sharp edges of about 4 msec. Note that since the smoothing is a lowpass filter, the highest frequency waves produced by the chip will be affected most.

If a panel control is needed, all that is required is a simple SPST switch from the pin to ground to switch waveform smoothing on or off.

Using potentiometers for CVs

The required control voltages can be produced directly from potentiometers as follows:

Note that if CV inversion is selected on pin 2 the “maximum” end of the pot should be connected to 0V and the “minimum” end should be connected to +5V!

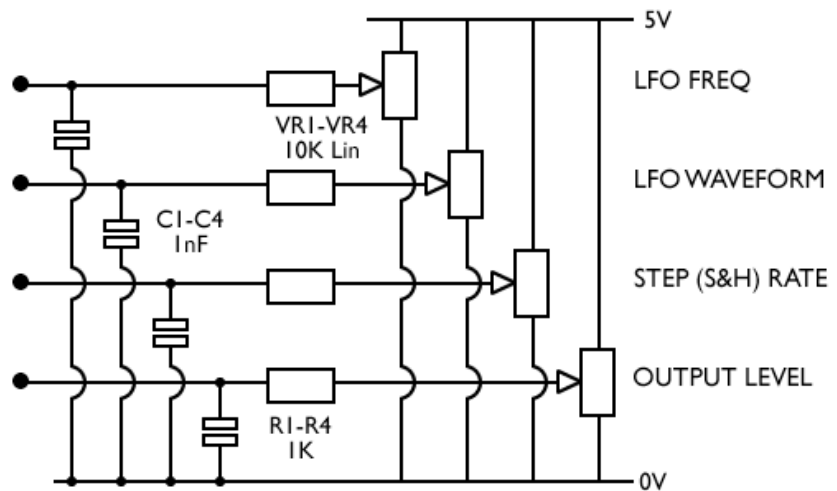

External CV inputs

External CV inputs can easily be combined with any of the controls by using an inverting op-amp mixer. This is shown in the example multi-waveform LFO schematic

Using a rotary switch to select LFO Range, Sync Mode, or Waveform

The LFO RANGE CV or SYNC MODE CV can either be generated by a pot as above, or selected using a 4-position switch, as shown below.

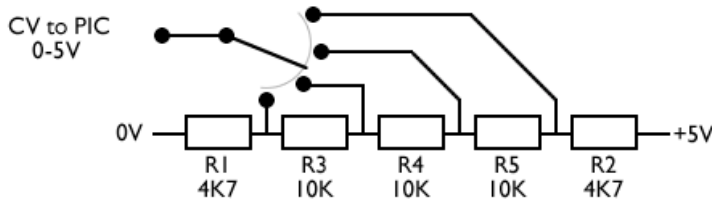

The same trick of using a tapped potential divider works for the Waveform CV.

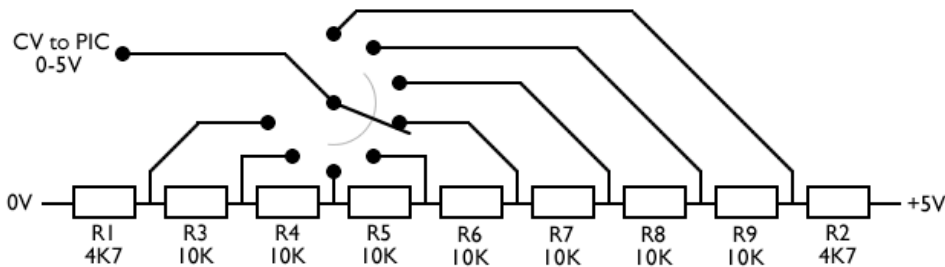

Using digital signals to select LFO Range, Sync Mode, or Waveform

In a programmable system, it is convenient to be able to select the waveform using digital signals. This can be done by converting them to a CV using a simple R-2R DAC.

Although we only require eight options, we use a 4-bit R-2R DAC design with the lowest bit tied high to ensure the output falls in the middle of the voltage range for each option.

A similar 3-bit R-2R DAC network can be used to generate CVs for LFO Range and Sync Mode by leaving off the uppermost 20K and 10K resistors for Bit 2 and taking the output from the junction at Bit 1 instead.

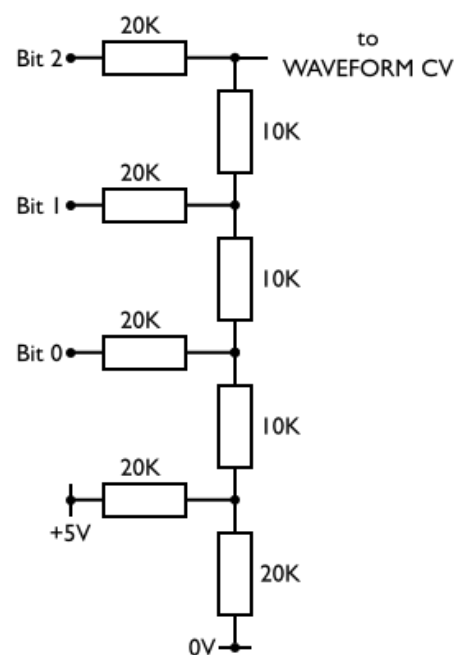



www.electricdruid.net

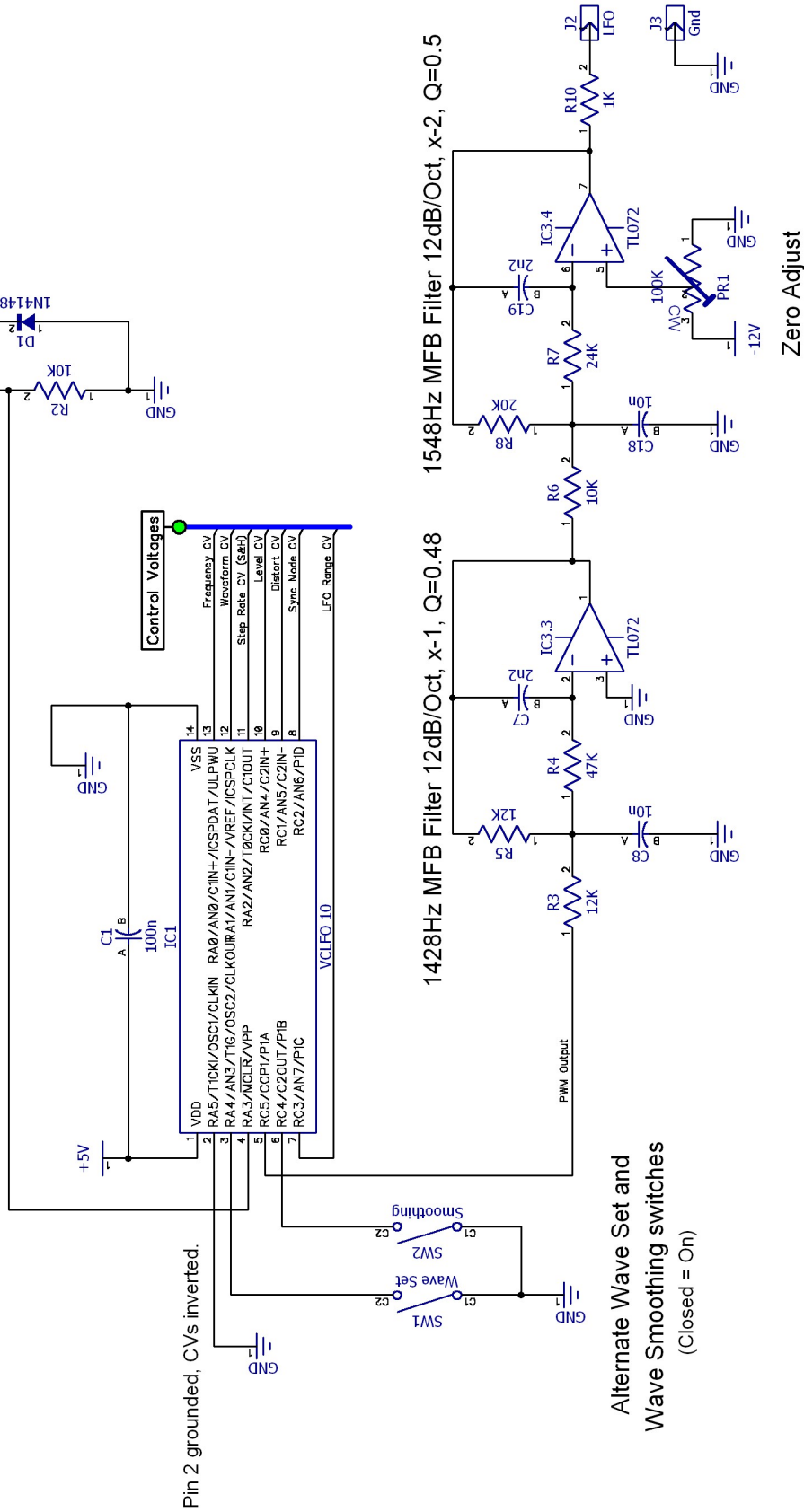

Electric Druid VCLFO 10

Shared under a CC BY-NC-SA 4.0 license. Some rights reserved.



Title		Processor and Output stages	
Size	Model	VCLFO 10	Rev
A4			2
Date	Drawn by		TMW
13 Apr 2026			
Filename	VCLFO10.dch		Sheet
			1 of 2



www.electricdruid.net

Power input

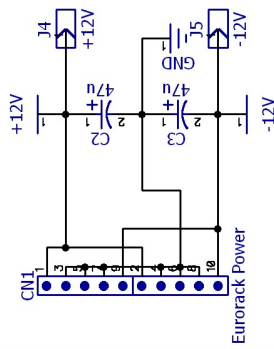

Op-amp power

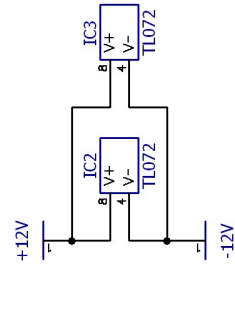

+5V power conditioning

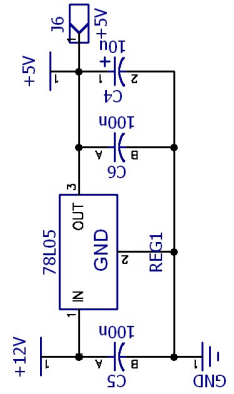

Frequency CV J7 -5V to +5V Freq CV

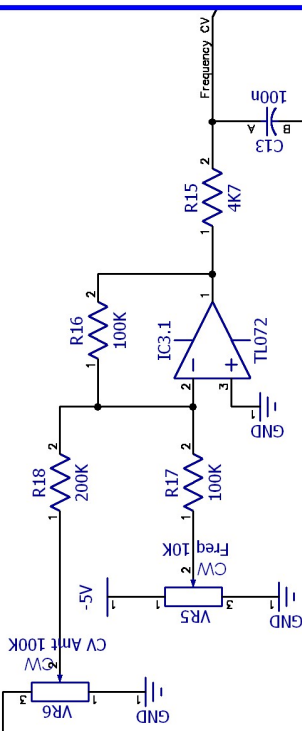

Level CV -5V to +5V

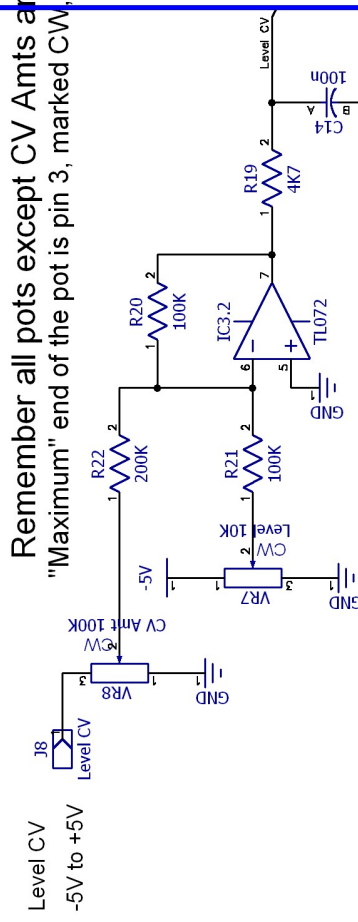

-5V offset reference

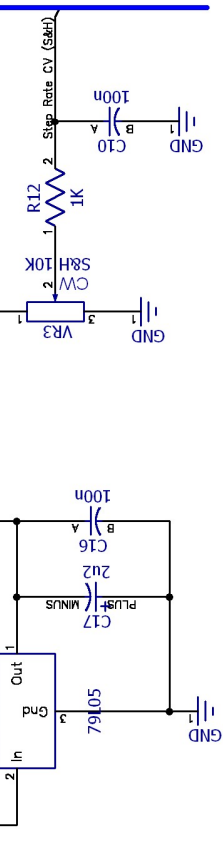

Remember all pots except CV Amt's are inverted!
"Maximum" end of the pot is pin 3, marked CW, the bottom

Control Voltages

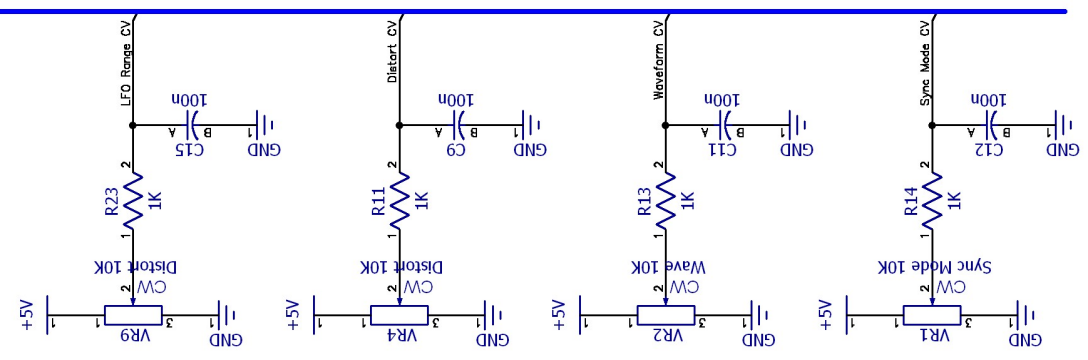

Electric Druid VCLFO 10

Rev.2: Corrected Sync Mode CV error

Title	Power, Controls Pots, and CV Inputs
Size	A4
Date	13 Apr 2026
Filename	VCLFO10.dch
Model	VCLFO 10
Rev	2
Drawn by	TMW
Sheet	2 of 2



Shared under a CC BY-NC-SA 4.0 license. Some rights reserved.

