

CEM 3372

μP Controllable Signal Processor

The CEM 3372 is a general purpose signal processing device for audio tone sources. Included on-chip are a two channel voltage controlled input mixer, a dedicated 4-pole low pass voltage controlled filter with voltage controllable resonance, and a quality final voltage controlled amplifier. With the exception of the filter cut-off frequency, all control inputs are very low bias current, high impedance inputs which range from 0 to +5 volts. This feature allows the common DAC output voltage in a microprocessor system to be multiplexed to these inputs with only a CMOS analog multiplexer and hold capacitors, thus eliminating the usual Sample & Hold buffers.

The two input VCAs of the mixer feature audio taper control scales and high attenuation at zero control voltage. The signal inputs are low level (80mV.P.P. for 5% THD), allowing multiple tone sources to be conveniently mixed into each channel.

A unique feature of the 24dB/octave filter is that, unlike others of this type, the passband gain remains constant as the amount of resonance is varied, thus eliminating the annoying drop in volume at higher resonance settings. Other features include wide frequency control range, temperature compensated transconductors, low noise, low control feed-through, and a smooth behaviour when swept.

The final output VCA is a current in, current out type, allowing multiple inputs to be easily mixed into its input, and easy interface of its output to the rest of the system. The control scale is very linear, and the point at which the VCA shuts off is very well defined (+100mV ± 50mV). Owing to its exceptionally low noise and exceptionally low control feedthrough without trimming, this VCA is well suited to being controlled by fast transient waveforms.

Features

- 2 Channel V.C. Input Mixer, 4-Pole Low Pass VCF, & Quality Final VCA all on One Chip
- Low External Parts Count
- 0 to +5V, High Z Control Inputs for Direct Interface to System DAC from CMOS Multiplexer
- VCF Uses Open Loop Design for Enhanced Sound Richness
- VCF has Constant Loudness as Resonance Changed
- TC Compensated VCF
- Low Level, Non-Inverting VCF Frequency Control Input for Easy Mixing of Control Sources
- Final VCA has Low Feed-through without Trimming

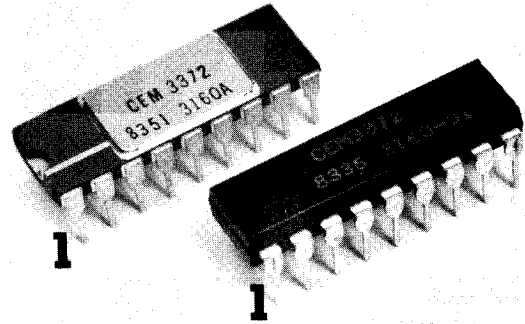

Block and Connection Diagram

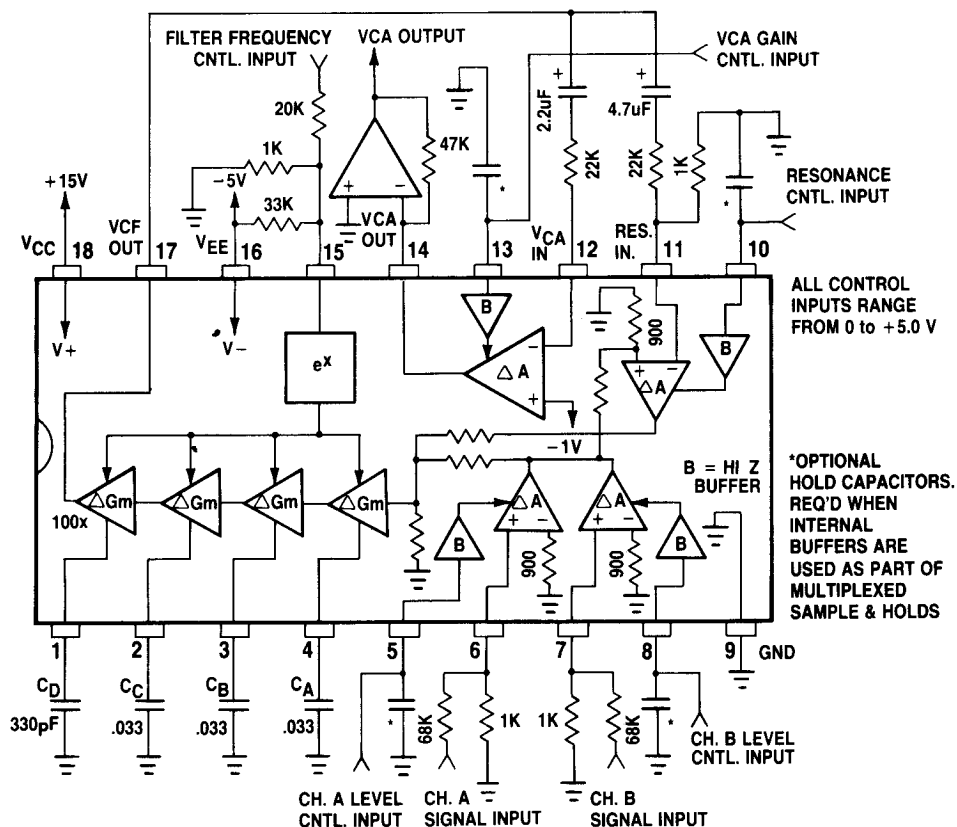

Inputs are 5Vpp nominal

CEM 3372

Electrical Characteristics

V _{CC} = +15V V _{EE} = -5V T _A = 20°C				
Parameter	Minimum	Typical	Maximum	Units
INPUT MIXER VCAs				
Gain Range for 0 - 5V Control	0-28.0	0-35.0	0-42.0	
Input Signal for 5% THD	—	75	—	mV.P.P.
Attenuation at V _{MIX} = 0	80	100	120	dB
DC Control Feedthrough	—	0.1	1.0	V
Signal Input Bias Current (V _{MIX} = +5V)	-0.1	-0.3	-1.0	μA
Mix Control Input Bias Current	-0.02	-0.1	-0.5	nA/V
Gain Variation (unit to unit)	—	0.7	±2.0	dB
VC FILTER				
Frequency Control Range	14	—	—	octaves
Frequency Control Voltage for 14 Octave Range	—	-155 to +110	—	mV
Frequency Control Scale	+17.5	+19.0	+20.5	mV/octave
Exponential Scale Error, Midrange	—	0.3	1.0	%
Initial Frequency at V _{FREQ} = 0 (C _A = C _B = C _C = 0.03μF; C _D = 300pF)	650	1000	1650	Hz
Frequency Control Input Bias	-0.3	-1.2	-3.5	μA
Resonance Control Range	Q = 0dB		oscillation	
Resonance Control Voltage Required for Oscillation	+2.2	+2.8	+3.4	V
Resonance Control Input Bias Current	-0.02	-0.1	-0.5	nA/V
Resonance Input Signal Gain for 0 - 5V Control	0 - 165	0-190	0 - 220	
Resonance Signal Input Bias (V _{RES} = +5V)	-0.3	-1.0	-3.0	μA
Maximum Output Swing:	9	10	11	V.P.P.
Nominal Output Swing for 5% THD (No Resonance)	2.2	2.5	2.8	V.P.P.
Nominal Output Swing with Resonance	4.4	5.0	5.6	V.P.P.
DC Output Shift Over 10 Octave Range (-130mV < V _{FREQ} < +60mV)	—	100	250	mV.P.P.
Output Noise, Filter Wide Open	—	—	200	μV.R.M.S.
Quiescent DC Output Voltage	+2.1	+2.8	+3.4	V
Output Sink Current	-0.4	-0.7	-1.0	mA
Output Source Drive Current	—	—	+3.0	mA
FINAL VCA				
Gain Control Range	100	120	—	dB
Maximum Signal Current Gain	0.80	0.93	1.10	
Control Voltage for Maximum Gain	4.5	5.0	5.5	V
Maximum Attenuation	90	120	—	dB
Control Voltage for Maximum Attenuation	+30	+85	+140	mV
Control Input Bias Current	±0.1	±0.5	±3.0	nA/V
Voltage at Signal Input Summing Node	-1.15	-1.0	-0.85	V
Output Voltage Compliance	-0.2	—	V _{CC} - 1	V
Maximum Recommended Signal Input Swing	—	—	±200	μA
Maximum Possible Signal Input Swing	±0.5	—	±0.8	mA
Output Noise	—	—	1.0	nA.R.M.S.
THD at ±200μA Input	—	1.0	3.0	%
DC Output Offset at Maximum Attenuation	—	—	1.0	nA
DC Output Shift from Maximum Attenuation to Maximum Gain	—	±0.07	±0.5	μA
GENERAL				
Positive Supply Range	+9.5	—	+18	V
Negative Supply Range (Maximum Supply Across Chip is 25V)	-4.5	—	-15.5	V
Supply Current	6.5	8.5	11.0	mA

CES
CURTIS ELECTROMUSIC SPECIALTIES